

## Safety Rope Pull Switch RPS

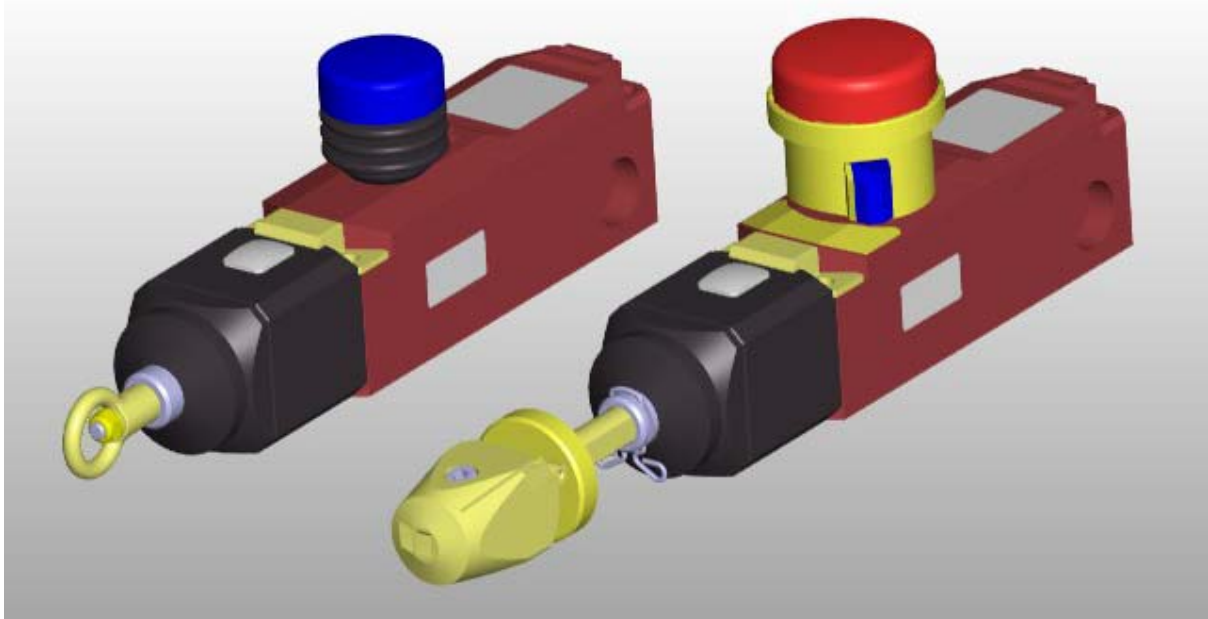

### Correct use

In accordance with EN 60947-5-5, EN ISO 13850, it must be ensured that parts of or complete industrial machines or installations can be stopped as quickly as possible by generation of an emergency stop signal. The purpose of these regulations is to prevent any danger for persons or damage to machines. The following applicable standards must be taken into account for this purpose:

**Regulations on installation and operation:** EN ISO 13849-1 Safety of machinery. Safety related parts of control systems.  
**Risk assessment on the machine:** EN ISO 14121-1, Safety of machinery. Principles for risk assessment.

The safety rope pull switches of the series RPS have been designed and tested in accordance with the standards laid down in EN 60947-5-5 and EN ISO 13850. They must be used only in control circuits. Safety rope pull switches are used on the accessible sides of conveyor systems or machines. In contrast to emergency stop switches (e.g. mushroom-head pushbuttons) located at certain intervals that allow the emergency stop signal to be generated only at the devices themselves, rope pull switches allow signal generation at any point along the rope length.

The plastic-encapsulated safety rope pull switches of the type RPS are intended for use only in closed areas.

### Design

Safety rope pull switches of the type RPS have a housing made of polyamide. They achieve the specified degree of protection IP67 if the cover is properly closed and if a cable gland is used that offers at least equivalent protection. The RPS has three cable entries M20x1.5.

The switches comply with the international requirements according to EN 60947-5-5, EN ISO 13850, i.e. after actuation or a rope tear, the emergency stop switch latches automatically, and the switch can then be reset to its initial state only by means of the resetting device on the switch.

Depending on the switch version, it is possible to achieve a rope tension length of 75 m. It must be taken into account here that the friction in the overall system can become so high due to the rope guides that this makes it difficult or impossible to reset the system (see section Installation).

This can be avoided by choosing different system components.

The user is responsible for ensuring that the system functions properly.

## Function

The system consists of the switching device, a red pull rope, supports and a counterspring. The pull device of the rope pull switch is connected with a pull rope. The emergency stop function can be tripped by pulling this rope. Since the rope pull system is pretensioned by an integrated spring, switch latching and the emergency stop function are tripped immediately if the rope tears. The safety contacts remain latched after tripping. After the hazardous situation has been remedied and after examination of the entire pull rope length, the system may be reset to operationally ready state again by manual operation of the reset button.

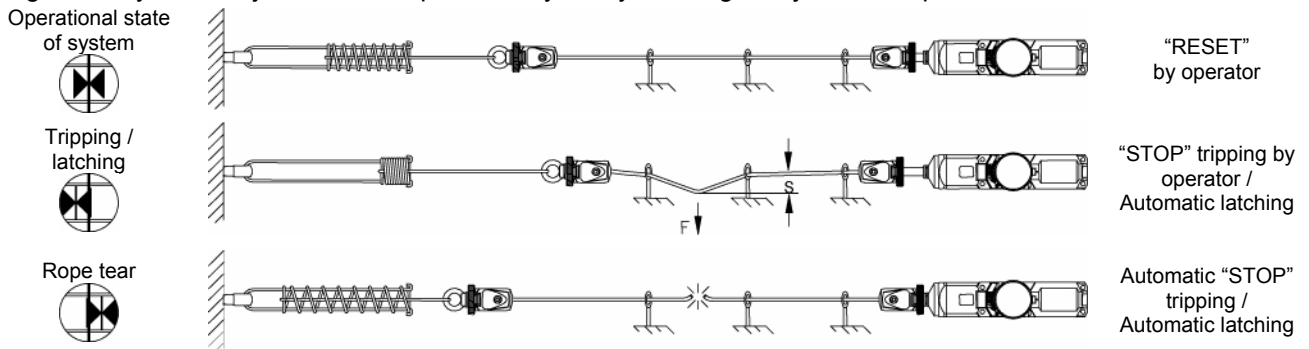

### RPS...S

The RPS...SC... switch types have an integrated red emergency stop slam button that can be actuated by pressing it if a hazardous situation occurs. Analogously to operation of the pull rope, the safety contacts are then opened and the switch is latched. After rectification of the hazardous situation, the system can be reset manually to operationally ready state by turning the actuating cylinder 90° in clockwise direction.

Please also refer to item 3 of the section *Installation sequence*!

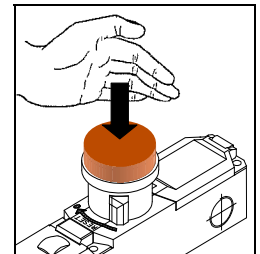

### RPS...P

After remedying the dangerous situation and with the rope system tensioned, the rope pull switch can be released and so made operational again by pulling the Reset knob.



## Safety precautions



- All system components must be mounted on surfaces that can reliably withstand all the forces that may occur.
- Routing of the rope as straight as possible results in low frictional forces in the system. From a rope length of 25 m, only rope pulley blocks may be used as rope supports. Rope pulley blocks and other accessories are optionally available.
- Positioning of the support points at irregular intervals prevents rope oscillations that might cause false tripping.
- The red pull rope must have sufficient space between the support points to ensure that secure gripping and tripping are possible. To improve visibility, marking flags can be attached to the pull rope along its length; however, these must not interfere with tripping of the emergency stop function!
- When a pull rope section is being set up and planned, it is necessary to take into account and comply with the applicable regulations, as well as the maximum permitted actuating travel of  $S = 400$  mm and maximum tripping force of  $F = 200$  N applied perpendicularly to the rope.
- Suitable guide rollers must be used for rope routing at angles.
- Improper installation or manipulation of the rope pull switch will lead to loss of the personal protection function and can cause serious or fatal injuries.
- Safety rope pull switches must not be bypassed (bridging of contacts), turned away, removed or otherwise rendered ineffective.
- The switching procedure must be triggered only by a pretensioned rope system when it is pulled or if the rope is torn.
- If damage or wear is found, the complete switch must be replaced. Replacement of individual parts or assemblies is not permitted!

## Identification of the safety rope pull switch

Identification by designation

e.g. **RPS-3131-SC-300M...**

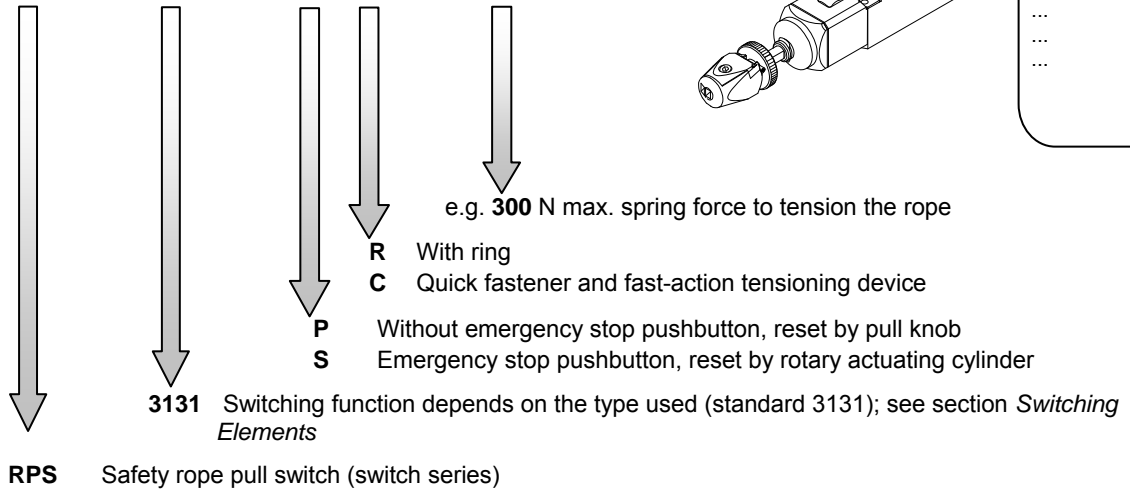
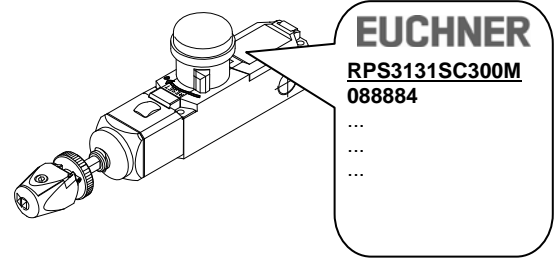

## Identification by item number

The item number of the switch is located beneath the switch designation on the switch label. Please state this number in correspondence and orders to EUCHNER GmbH + Co. KG.

## Dimensions

### RPS...PR...

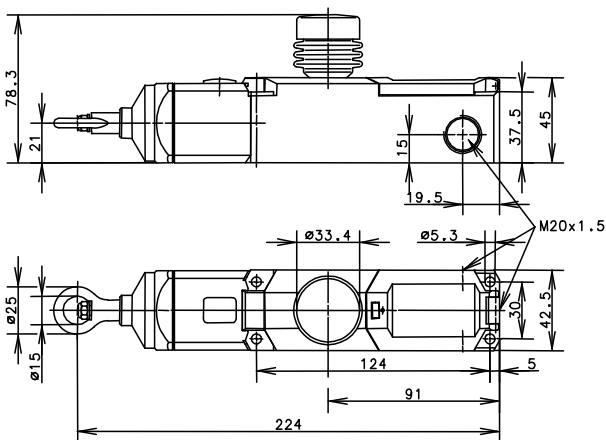

### RPS...PC...

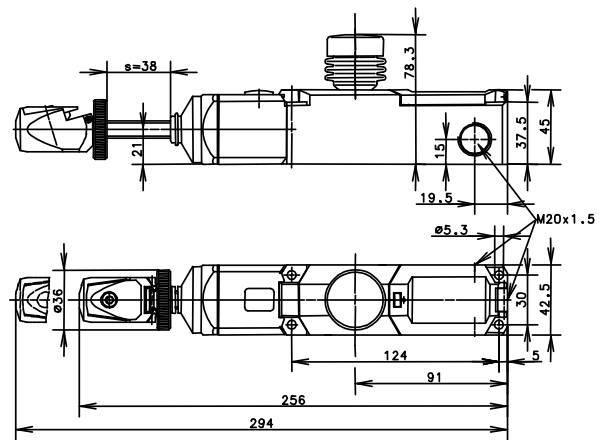

### RPS...SC...

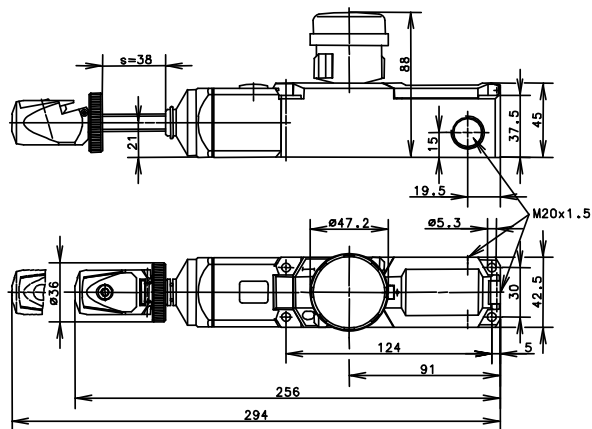

All dimensions in millimeters

## Installation

### Note

Under ideal installation conditions it is possible to achieve a maximum rope tension length of 75 m. Depending on the actual situation, there may be increased friction in the system. This friction may be so high that automatic returning to reset position as shown below is no longer possible. However, tripping in the event of a rope tear must be guaranteed in all cases.

The amount of friction depends on:

- Number of eyebolts used
- Number of contact angles and deflections
- Number and size of guide rollers
- Alignment of rollers and eyebolts with respect to each other.

The friction can be reduced by using guide rollers with a larger diameter. The system should be divided up if there is too much friction. The user is responsible for component selection and correct functioning of the system.

### Example for correct installation

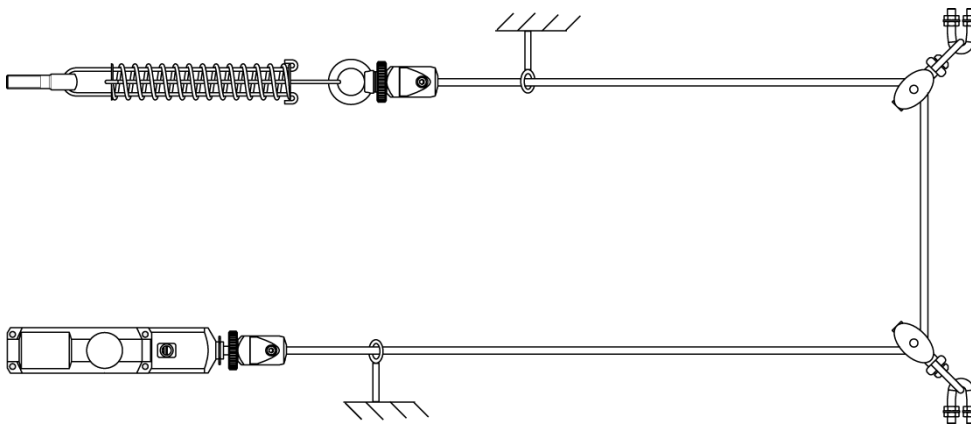

### Example for incorrect installation

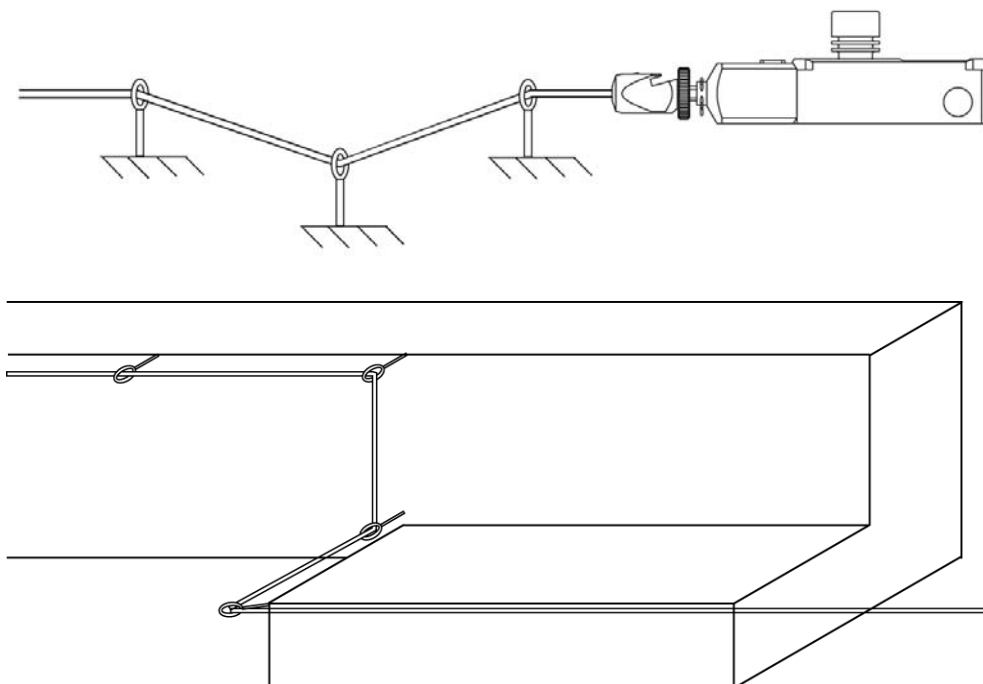

### Selection of system components

A tensioner spring must be installed on the thrust bearing in order to ensure proper and safety-compliant realization of the pull rope system. This is a precondition for direction-independent tripping at any point along the rope length. In order to achieve fast and simple compliance with this requirement, we recommend the use of EUCHNER tensioner springs with integrated overstretch protection (see Table 1). Additional fixing and installation materials as well as ropes are also optionally available. A detailed overview is provided in the section *Accessories*.

**Tensioner spring**

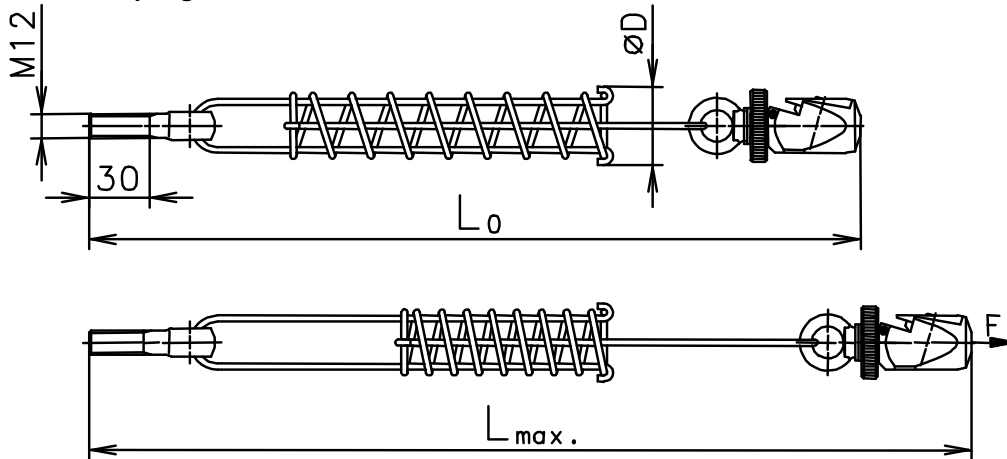

**Table 1**

RPS type	RPS...100/175	RPS...300
<b>Item number</b>	<b>092136</b>	<b>092138</b>
$L_{0\ min.}$ [mm]	383	483
$L_{max.}$ [mm]	487	653
$\varnothing D$ [mm]	39	48

Tensioner springs are supplied with quick fastener and an eyebolt DIN 444 - M12 x 50

When installing and adjusting the rope pull switch, it is necessary to take into account the physical changes in the rope length as a result of variations in temperature.

Table 3 shows the permitted rope tension lengths as a function of the expected temperature difference. The diagram also shows the maximum permitted rope tension length for the different spring forces of the respective switch types. It also permits selection of the appropriate switch corresponding to the expected temperature variations.

### Recommended rope length dependent on ambient temperature

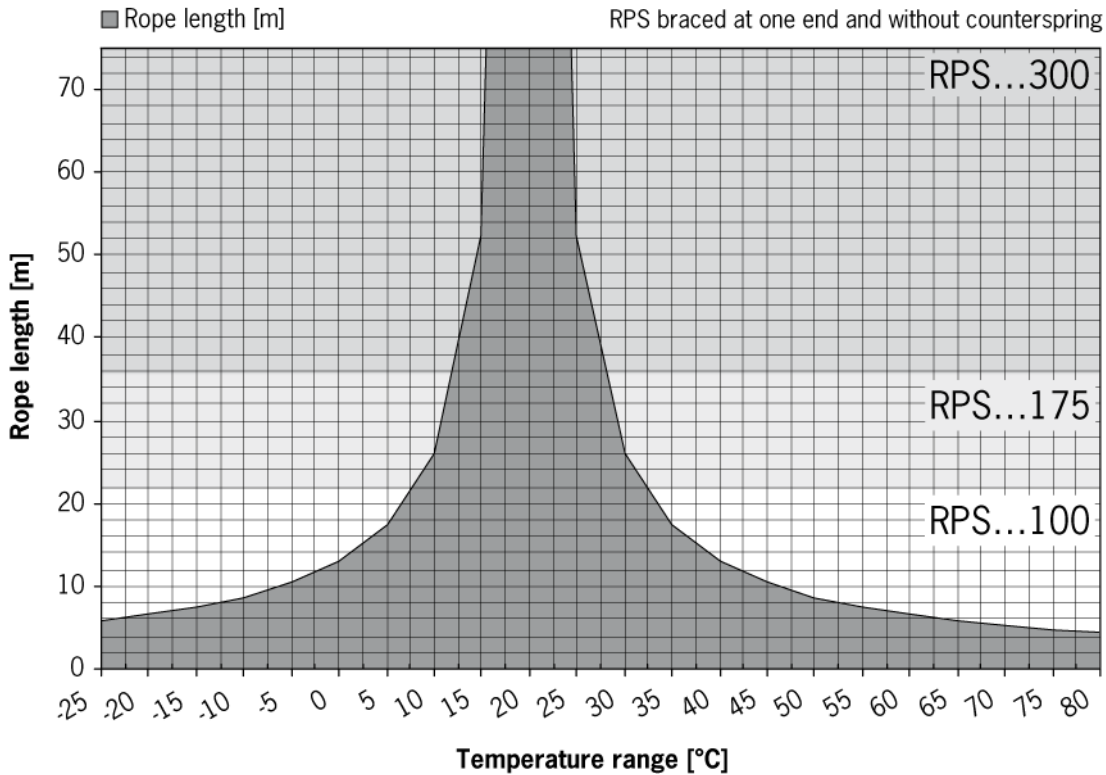

Table 3

	Rope tension length Lmax. in meters [m]																																																																										
	1	2	3	4	5	6	7	8	9	10	11	12	13	14	15	16	17	18	19	20	22	24	26	28	30	32	34	36	38	40	42	44	46	48	50	55	60	65	70	75																																			
Max. temperature variation in Kelvin	+/- 40 K																																																																										
	+/- 35 K																																																																										
	+/- 30 K																																																																										
	+/- 25 K																																																																										
	+/- 20 K																																																																										
	+/- 15 K																																																																										
	+/- 10 K																																																																										
	+/- 5 K																																																																										
+/- 3,5 K																																																																											
RPS...100	Rope tension length max. 25 m																																																																										
RPS...175	Rope tension length max. 37.5 m																																																																										
RPS...300	Rope tension length max. 75 m																																																																										

Rope supports must be provided at intervals of 2–5 m when planning and installing the system. Refer also to the section *Safety precautions*.

## Installation sequence

Installation must be performed only by authorized personnel.

**1 A**

1.1A 1.2A 1.3A SW4

Attach bearing element with tensioner spring; fit pull rope: sheathing must be removed in clamping area; insert rope in the fast-action clamping head as shown and secure

**B**

1.1B 1.2B

Attach bearing element with counterspring; fit pull rope: secure rope as shown with thimble and rope clamp, attach rope bridge to limit travel of counterspring with thimbles and rope clamps

**2**

rope tension

2 - 5 m

La = 150 mm

Observe distance to the 1st support point. The 1st rope support next to the switch must be installed after La = 150 mm.  
Install supports at intervals of 2 – 5 m.

**3**

Secure RPS switch with 4 screws M5.  
Maximum tightening torque M = 2 Nm

The emergency stop switches must be positioned so that the rope or emergency stop slam button can be reached without obstacles in hazardous situations.

Display

M5

37.5 (1.48")

37.5 (1.48")

M20x1.5

124 (4.88")

30 (1.18")

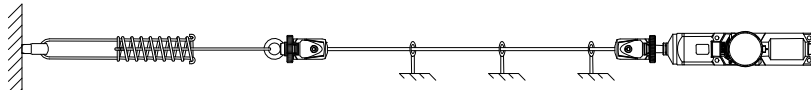
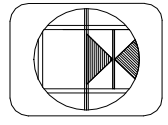
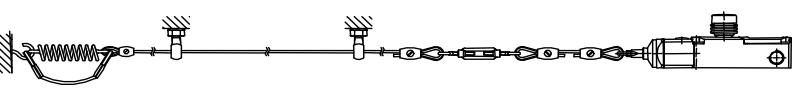
<p><b>4 A</b></p>  <p>Connect pull rope with fast-action clamping head (see Item 1). Pretension pull rope.</p>	<p>Display:</p> 
<p><b>B</b></p>  <p>Connect pull rope with turnbuckle as shown (3x rope clamp with thimble)</p>	

**5** Basic setting should take place at a temperature corresponding to the prevailing operating conditions. The length of the pull rope changes if there is a large change in the ambient temperature. Under these conditions, long rope lengths mean a frequent change in the basic setting. This can be remedied by re-adjustment (Item 5) or shortening the rope length (Table 3).

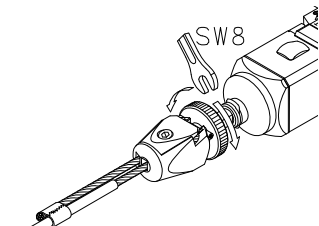
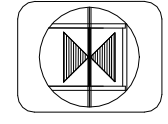
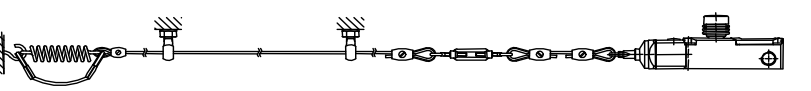
<p><b>A</b></p>  <p>Adjust the setting ring until the arrow tips of the display are flush with the marking.</p> <p>Hold the fast-action clamping head tight when doing this to prevent the pull rope twisting.</p>	<p>Display:</p> 
<p><b>B</b></p>  <p>Adjust the turnbuckle until the arrow tips of the display are flush with the marking.</p>	

## Mechanical function test

**6 A RPS...PR/PC**

Pull up blue RESET knob:  
- safety contacts closed.

Actuate the pull rope:  
- safety contacts open

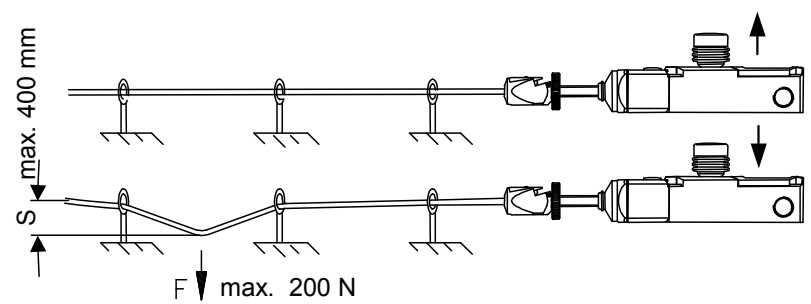

**B RPS...SC...**

Turn yellow actuating cylinder at the RESET contact areas (blue) by 90° up to the marking, then release. Cylinder returns to initial position.

For each test procedure:  
Operate EMERGENCY STOP button or pull rope.

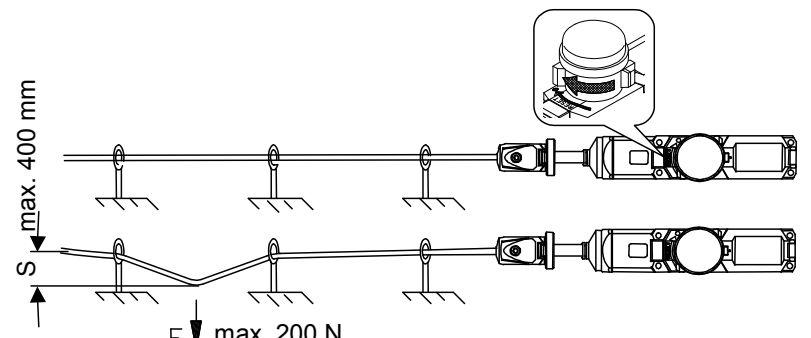

Operate the pull rope forcefully several times in order to settle the pull rope section. If necessary, carry out re-adjustment by means of the adjusting screw / turnbuckle.

## Electrical connection

Electrical connection must be performed only by authorized personnel

1. Release cover using a screwdriver
2. Open break-out wall by screwing in the cable gland, remove the plastic part
3. Tight cable gland
4. Connection to cage pull spring
5. Insert screwdriver (2.5 mm blade width) **(1)** into bottom opening
6. Turn screwdriver by 45° **(2)**
7. Insert flexible cable with a cross-section of 0.08 ... 1.5 mm<sup>2</sup> in the upper opening **(3)**.  
The cable end must be fitted with a wire end ferrule.
8. Remove screwdriver.
9. Press on cover.

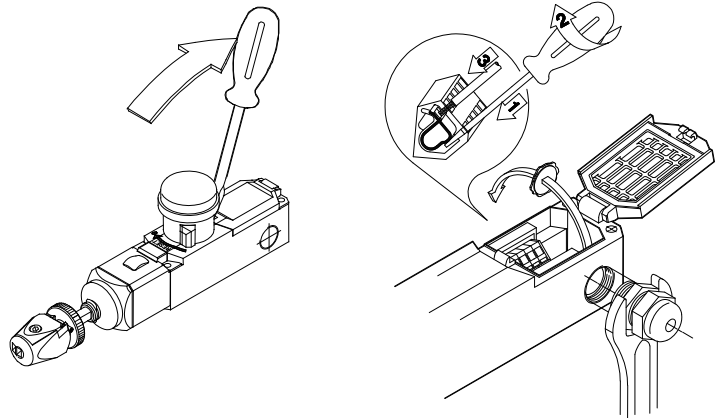

### Connection example

The following connection example shows a possible circuit with a redundant circuit design even on drive control level.

The signal of the emergency stop chain is evaluated here by a safety relay (ESM from EUCHNER).

The overall control concept which includes the safety cable switch RPS must be validated by the final user/machine designer corresponding to DIN EN ISO 13849-2.

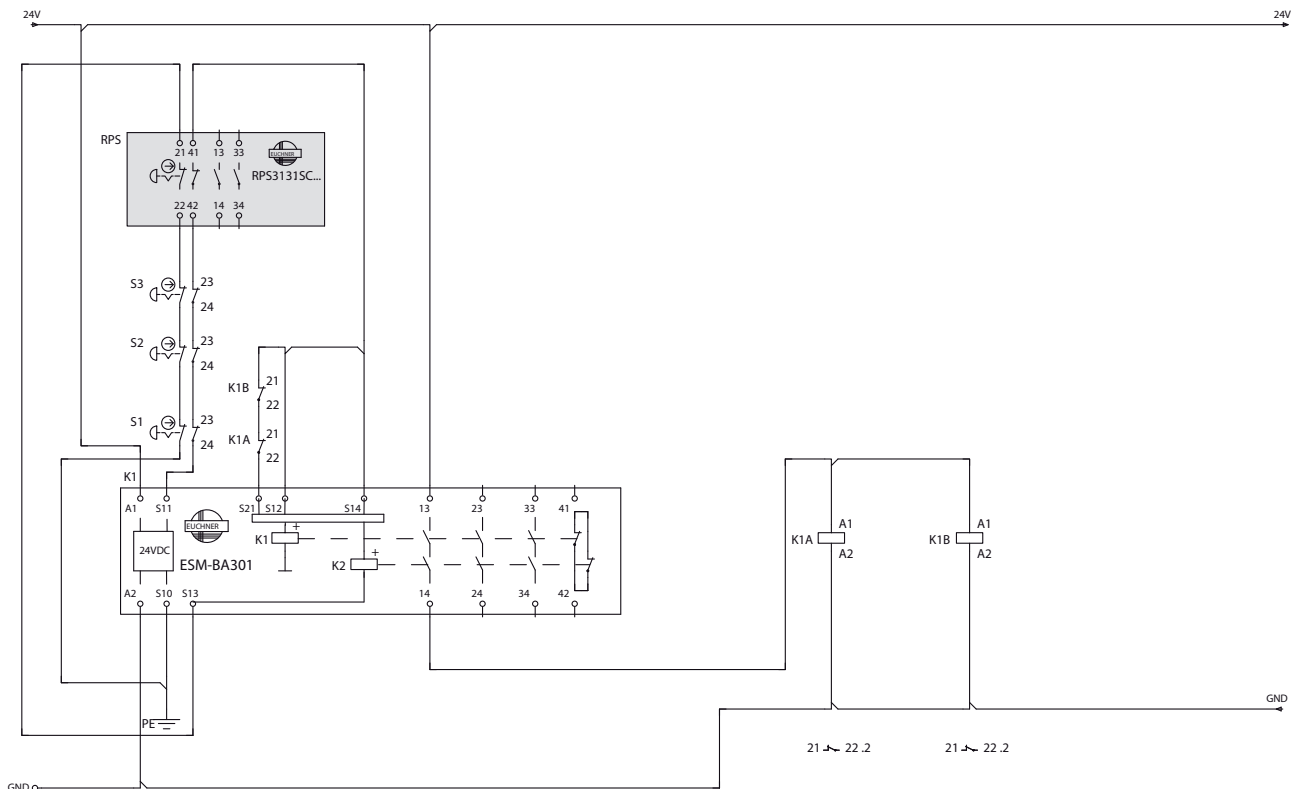

## Setup

### Mechanical function test

It must be possible to actuate the pull rope easily at every point of the rope pull system. As a check, actuate the pull rope several times.

### Electrical function test

Activate the rope pull system by means of the RESET actuating cylinder.  
Start the installation/machine.

Actuate the pull rope / EMERGENCY STOP button: this results in the safety contacts opening immediately. ⊖

The safety contacts close only after renewed operation of the RESET actuating cylinder. ⊕

### Electrical data (this data refers to switches without plug connector)

Rated insulation voltage	$U_i$	250 V
Rated impulse withstand voltage	$U_{imp}$	2,5 kV
Continuous thermal current	$I_{the}$	10 A
Utilization category		AC 15; 230 V/ 3 A
Short circuit protection		6 A gG according to IEC 60269-1
Protection class		II
Positively driven NC contacts		⊖ IEC/ EN 60947-5-1, Annex K

### Mechanical data

Housing	PA 6 GV (UL94-VO)
Cover	PA 6 GV (UL94-VO)
Actuation	Die-cast zinc/steel
Ambient temperature	-25 °C to +70 °C
Contact opening gap	> 2 x 2 mm
Mechanical life	Acc. to IEC 60947-5-5
Switching frequency	≤ 20/min.
Latching device	Acc. to EN 60947-5-5, DIN EN 418
Emergency stop reset	RPS...SC : By turning the RESET actuating cylinder RPS...PR/PC: By pulling the blue RESET knob
Rope length	$L_{max} = 75 \text{ m} / 37.5 \text{ m} / 25 \text{ m}$ , depending on type (observe Table 3)
Rope diameter	$D = \varnothing 2 - 5 \text{ mm}$
Rope attachment	RPS...SC/PC... Fast-action clamping device / PR... By means of ring
Connection type	8 x cage pull springs 0.08 ... 1.5 mm <sup>2</sup> flex.
Cable entry	3x M20x1.5
Mounting	4x M5
Weight	approx. 0.65 kg
Degree of protection	IP 67 acc. to EN 60529

### Regulations

EN 60947-1, EN 60947-5-1, EN 60 947-5-5, EN ISO 13850

### EC conformity

### Approvals

c CSA us / BG

## Switching Elements

The values for the tensile force depend on the switch type used. (RPS...100/RPS...175/RPS...300)  
Tolerance: tensile force  $\pm 15\%$

### 3131 (standard)

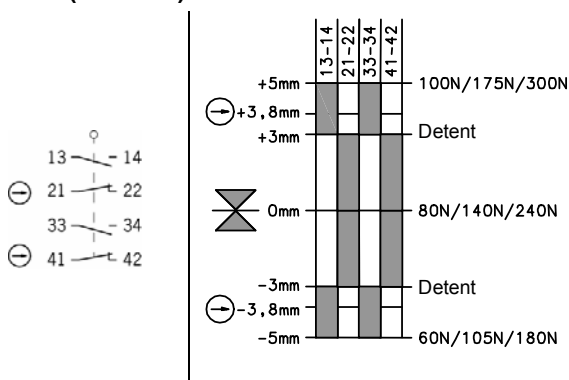

### 2131

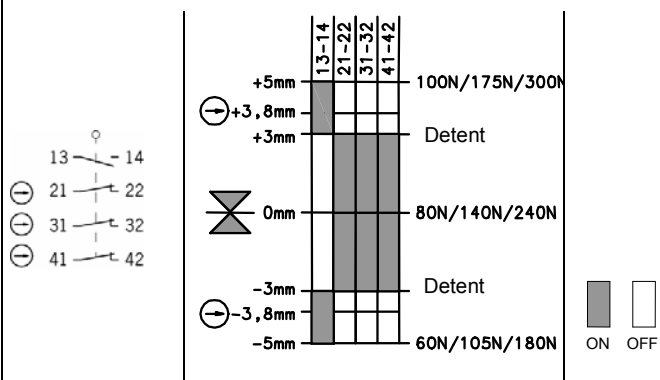

## Maintenance and servicing

In order to ensure trouble-free, long-term operation, it is necessary to perform regular, documented inspection of the following:

- Smooth actuation
- Correct switching function
- Correct rope tension
- Secure mounting of components
- Dirt deposits and wear
- Sealing of cable entry
- Loose cable connections or plug connectors.

After servicing or repair, correct functioning of the system should be checked by actuating the pull rope several times. It must be ensured that the switch latches properly after actuation.

In the event of a fault in the switching system or latching device, the switch must be replaced and can be sent to EUCHNER GmbH + Co. KG for inspection.

## Exclusion of liability

The manufacturer's liability will be rendered void if the instructions are not followed (proper use, safety precautions, installation and connection by trained personnel, checking of reliable functioning).

## Accessories

Designation	Description/Version	Packaging unit	Order No.
<b>Eyebolt</b>	Thread M8	5 ea.	<b>092495</b> RPS-O-8-50/V5
<b>Rope set</b>	Consisting of thimble and rope clamp	5 ea.	<b>092496</b> RPS-RS/V5
<b>Pulley set RPS</b>	rope pulley with swiveling lug (rollers- $\varnothing$ 6mm) and clamp	5 ea.	<b>092501</b> RPS-PS/V5
	rope pulley (rollers- $\varnothing$ 14mm) and clamp	1 ea.	<b>096251</b> RPS-P/V1
<b>Tensioning rope</b>	Length 50m	1 ea.	<b>092813</b> RPS-I-3-4/50M
	Length 100m	1 ea.	<b>092814</b> RPS-I-3-4/100M
<b>Built-in LED</b>	light radiation to side	1 ea.	<b>087423</b> LED M20x1,5
	light radiation to front	1 ea.	<b>095510</b> LED M20x1,5
<b>Turnbuckle</b>	M6 x 60	5 ea.	<b>092498</b> RPS-B-6-60/V5
	M6 x 110	1 ea.	<b>092500</b> RPS-B-6-110
<b>Tensioner spring</b>	for RPS 100, 175	1 ea.	<b>092136</b> RPS-W-100-175
	for RPS 300	1 ea.	<b>092138</b> RPS-W-300

Euchner GmbH + Co. KG  
Kohlhammerstraße 16  
D-70771 Leinfelden-Echterdingen  
info@euchner.de  
www.euchner.de

Issue:  
090276-05-10/08  
Title: Operating Instructions for Rope Pull Switches RPS  
Copyright:  
© EUCHNER GmbH + Co. KG, 10/2008

Subject to technical modifications; no responsibility is  
accepted for the accuracy of this information

0800000388

More than safety.

---



**EUCHNER**